

General Claim Form



The issue and acceptance of this form does not constitute an admission of liability on the part of the insurer or its agent.

Ryno Insurance Services, a specialist division of East West Insurance Brokers Pty Ltd,
 ABN 83 010 630 092, AFSL No: 230041, 19 Rosedale Street, Coopers Plains. Qld. 4106.
 Phone: 1300 650 670 Fax: 07 3344 2448.

Policy Number	
----------------------	--

Claim Number	
---------------------	--

Please complete all sections. Important: Attach one quotation from repairer.

Insured Details									
Full Name (Block Letters)	Surname				Given Name(s)				
Postal Address							State	Postcode	
Are you registered for GST?	No <input type="checkbox"/> Yes <input type="checkbox"/>	What is your ABN?							
Have you claimed or intend to claim an input tax credit on the GST component of the premium applicable to the Policy?	No <input type="checkbox"/> Yes <input type="checkbox"/> – Will you be claiming an amount less than 100%?								
	No <input type="checkbox"/> Yes <input type="checkbox"/> – Specify amount claimed						%		
Are you entitled to claim an input tax credit for repairs or replacement of the item that has been lost or damaged?	No <input type="checkbox"/> Yes <input type="checkbox"/> – Will you be claiming an amount less than 100%?								
	No <input type="checkbox"/> Yes <input type="checkbox"/> – Specify amount claimed						%		
Contact Numbers	Business	()			Private	()			
	Facsimile	()			Mobile				

Vehicle Details									
Make of Vehicle				Year	/	/	Registered No.		
Model				Colour			Odometer Reading		
Registered Owner									
Address							State	Postcode	
Do you owe money on your vehicle?							No <input type="checkbox"/> Yes <input type="checkbox"/> – Give details		
Name of Lender				Account Number					
Address							State	Postcode	

Driver Details									
Full Name (Block Letters)	Surname				Given Name(s)				
Address							State	Postcode	
Contact Numbers	Business	()			Private	()			
	Facsimile	()			Mobile				
Relationship to Insured									
Licence Number				Expiry Date	/	/	Date of Birth	/	/
How long has the driver been licensed for this type of vehicle?				years					
Did the driver drink any alcohol or take any drugs in the 24 hours prior to the accident?							No <input type="checkbox"/> Yes <input type="checkbox"/> – Give details		
Did the driver undergo a breath test, breath analysis or blood test?							No <input type="checkbox"/> Yes <input type="checkbox"/> – Give details		
What was the reading?				(Please attach copy of the certificate.)					

Incident Details

Date	/ /	Day		Time	am/pm
Where did the incident happen?					
Street		Suburb		Nearest Cross Street	
Road surface: Dry <input type="checkbox"/> Wet <input type="checkbox"/> Loose <input type="checkbox"/>					
At the time of the accident the insured vehicle was: Parked <input type="checkbox"/> Stationary <input type="checkbox"/> Moving <input type="checkbox"/> Speed					
Traffic controls: None <input type="checkbox"/> Stop sign <input type="checkbox"/> Traffic Lights <input type="checkbox"/> Roundabout <input type="checkbox"/> Give way sign <input type="checkbox"/> Other <input type="checkbox"/>					
Number of other vehicles involved					
If applicable, what type of goods were being transported at time of loss?					
What happened?					

Who was at fault?	Surname	Given Name(s)
-------------------	---------	---------------

SKETCH DIAGRAM OF ACCIDENT

<p>1. Name streets</p> <p>2. Indicate direction of travel</p> <p>3. Your vehicle <input checked="" type="checkbox"/></p> <p>4. Other vehicle <input type="checkbox"/></p>	
---	--

Damage to Your Vehicle

Are you claiming for the damage to your vehicle?		No <input type="checkbox"/> Yes <input type="checkbox"/>
Was the vehicle towed?		No <input type="checkbox"/> Yes <input type="checkbox"/> - Give details
Name of tow company		
Where was it towed?	Distance towed	Kms
Where is vehicle now?		

SKETCH DIAGRAM

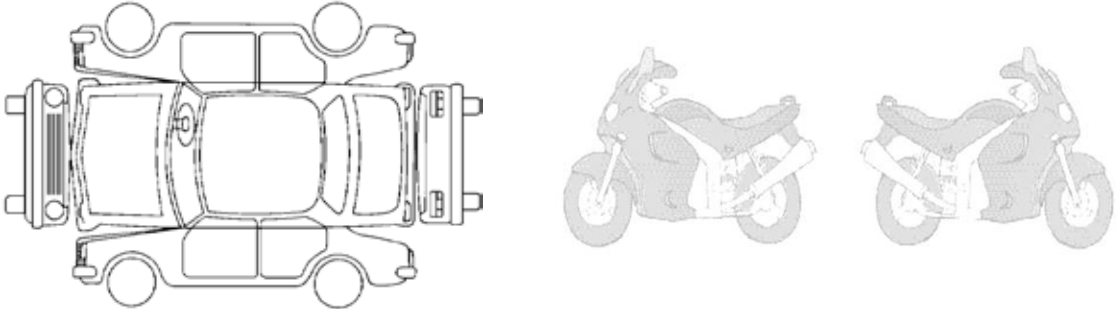
<p>Shade in damage to vehicle.</p> <p>Indicate point of impact (X)</p>	
--	--

Owner of Other Vehicle

Name	Surname	Given Name(s)
Address		
	State	Postcode
Contact Numbers	Business ()	Private ()
Insurance Co.	Policy No.	

Driver of Other Vehicle				
Name	Surname		Given Name(s)	
Address				State
				Postcode
Contact Numbers	Business	()	Private	()
Date of Birth	/ /	Driver's Licence Number		
Was the owner in the vehicle at the time of the accident?				No <input type="checkbox"/> Yes <input type="checkbox"/>
IF THERE IS MORE THAN 1 OTHER VEHICLE INVOLVED PLEASE ATTACH DETAILS.				

Other Vehicle			
Registration No.	Year of Manufacture	Make of vehicle	
Model		Colour	

Damage to Other Vehicle	
Details of damage to other vehicle	

Other Parties			
Give details of pedestrians, owners of property or owners of animals involved.			
Name	Surname		Given Name(s)
Address			State
			Postcode

Police			
Did a Police Officer attend the accident scene, No <input type="checkbox"/> Yes <input type="checkbox"/> or did you report the incident to the police? No <input type="checkbox"/> Yes <input type="checkbox"/> – Give details			
Name			Rank
Station			
Date of report	/ /	Police Report #	
Name of person to be charged or cautioned			
Nature of charge or caution			

Witness(es) Details			
Name	Surname		Given Name(s)
Address			State
			Postcode
Contact Numbers	Business	()	Private ()
Was this witness in the insured vehicle?			No <input type="checkbox"/> Yes <input type="checkbox"/>
Name	Surname		Given Name(s)
Address			State
			Postcode
Contact Numbers	Business	()	Private ()
Was this witness in the insured vehicle?			No <input type="checkbox"/> Yes <input type="checkbox"/>

Owner(s) and Driver History

In the last 5 years have you as owner or the driver of this vehicle:

1. Had an insurance refused, declined or cancelled by an insurer or any special conditions imposed? Yes No
2. Been convicted, fined or charged with:
 - a) Drug use, driving under the influence, or exceeding Prescribed Concentration of Alcohol? Yes No
 - b) Any driving offences or speeding ? Yes No
 - c) Fraud, arson, theft or any other criminal act? Yes No
3. Had a drivers or motorcycle licence cancelled, suspended or endorsed? Yes No
4. Had a claim or accident? Yes No
5. Had a car stolen or burnt out? (include any not reported or not claimed from an insurer) Yes No
6. Suffered or suffer from impaired eyesight (excluding wearing of glasses), loss of or use of any limb or loss of hearing or from any physical defect or epileptic, diabetic, heart or mental condition? Yes No

If you answered "Yes" to any of the above questions please provide relevant details below

Name of Driver	Date of Incident	Details of each Incident	Your Insurer	Person at Fault

If there is insufficient space, please attached a sheet with the relevant information.

Privacy

Ryno Insurance Services provides full details of how we manage and use your personal details, either on our website or in our Product Disclosure Statements. You can obtain a copy from our website at www.rynoinsurance.com.au or call us on 1300 650 670 to request a copy.

Our Complaints and Disputes Policy

If you have a complaint about how we handle your claim, please contact us. We have an internal dispute resolution process to assist you. If you are not satisfied with our response, and wish to proceed with your complaint, you may contact the insurer. The insurer/s subscribe to the Financial Ombudsman Service www.financialombudsman.com.au which is an external disputes facility and a free service to you. Also see our complaints handling procedures at www.rynoinsurance.com.au

Declaration and Authorisation

The information and answers given above are true, correct and complete in every detail.

1. I/We understand the claim may be refused if information is not true or is withheld.
2. I/We authorise Ryno Insurance to give to and obtain from other insurers, insurance reference bureaus and credit reporting agencies any information relating to the Insured's credit or insurance history as well as insurance claims information obtained during the course of this contract.

Signature of Insured 1. Date / /

Signature of Insured 2. Date / /

PLEASE CHECK THAT THIS FORM HAS BEEN FULLY COMPLETED AS ANY OMISSIONS MAY DELAY YOUR CLAIM, AND RETURN IT TO RYNO INSURANCE SERVICES 19 Rosedale Street, Coopers Plains Qld 4108. Fax 07 3344 2448, or claims@rynoinsurance.com.au, or as requested in attached correspondence.

IMPORTANT NOTE:- Ryno Insurance Services acts under a binding authority given to it by the insurer/s to arrange, issue and administer policies. Additionally, for those policies insured by Lloyd's, Ryno Insurance Services also settle claims on behalf of that insurer. When acting under such authorities, Ryno Insurance Services acts on behalf of the insurer/s and not for you. Please refer to your Product Disclosure Statement and Policy or call us for more information.